

BLACKMER PARTS LIST

960267 PARTS LIST
Page 1 of 4 109-C00

With Installation and Maintenance Instructions HELICAL GEAR REDUCERS MODEL: HRB

Section 109
Effective Apr 2010
Replaces Oct 2007



This is a SAFETY ALERT SYMBOL.

When you see this symbol on the product, or in the manual, look for one of the following signal words and be alert to the potential for personal injury, death or major property damage



Warns of hazards that WILL cause serious personal injury, death or major property damage.



Warns of hazards that CAN cause serious personal injury, death or major property damage.



Warns of hazards that CAN cause personal injury or property damage.

NOTICE:

Indicates special instructions which are very important and must be followed.

NOTICE:

Blackmer gear reducers **MUST** only be installed in systems, which have been designed by qualified engineering personnel. The system **MUST** conform to all applicable local and national regulations and safety standards.

These instructions are intended to assist in the installation of and maintenance of the Blackmer gear reducer, and **MUST** be kept with the reducer.

Blackmer gear reducer service shall be performed by qualified technicians **ONLY**. Service shall conform to all applicable local and national regulations and safety standards.

Thoroughly review this manual, all instructions and hazard warnings, **BEFORE** performing any work on Blackmer gear reducer.

Maintain **ALL** system and Blackmer pump and reducer operation and hazard warning decals.

NOTICE:

Pump manuals, parts lists and other needed literature may be obtained from the Blackmer website (www.blackmer.com) or by contacting Blackmer Customer Service.

WARNING



Hazardous voltage.
Can shock, burn or cause death.

Failure to disconnect and lockout electrical power before attempting maintenance can cause shock, burns or death

WARNING



Hazardous or toxic fluids can cause serious injury.

If pumping hazardous or toxic fluids, system must be flushed and decontaminated, inside and out, prior to performing service or maintenance

WARNING



Hazardous pressure can cause personal injury or property damage

Disconnecting fluid or pressure containment components during pump operation can cause serious personal injury, death or major property damage

WARNING



Hazardous machinery can cause serious personal injury.

Failure to disconnect and lockout electrical power or engine drive before attempting maintenance can cause severe personal injury or death.

WARNING



Hazardous pressure can cause severe personal injury or property damage

Failure to relieve system pressure prior to performing pump service or maintenance can cause severe personal injury or property damage.

CAUTION



Extreme heat can cause injury or property damage.

Failure to allow gear reducer to cool before attempting maintenance can cause serious personal injury.

NOTE: Numbers in parentheses following individual parts indicate reference numbers on the corresponding Lip Seal Parts Lists.

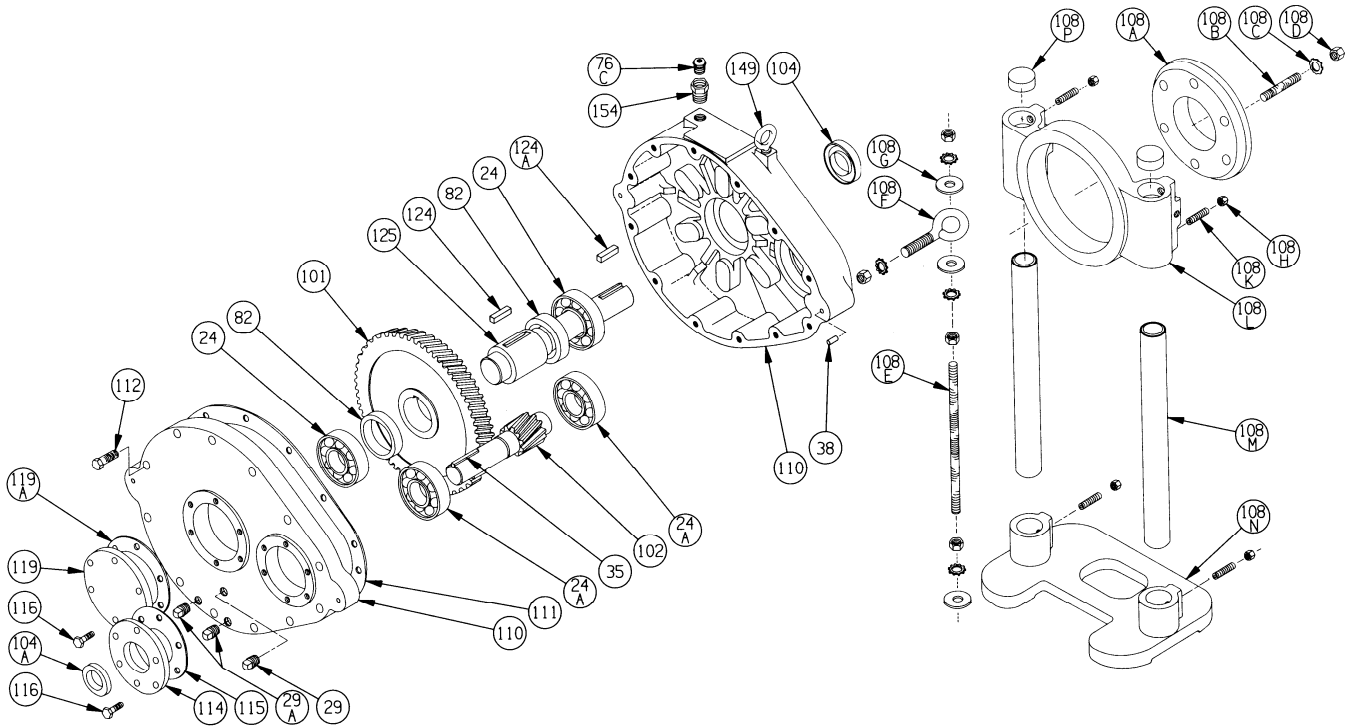

Ref. No.	Description	Parts per Unit	Part No.	Ref. No.	Description	Parts per Unit	Part No.
24	Bearing	2	903130	124	Key – Gear	1	909179
24A	Bearing	2	903150	124A	Key – Shaft	1	909182
29	Oil Level Plug	1	908198	125	Shaft	1	704021
29A	Drain Plug	2	908100	149	Eyebolt	1	922450
35	Key – Pinion	1	909177	154	Bushing	1	908794
38	Dowel Pin	2	930739		BRACKET ASSEMBLY		871085
76C	Fill & Vent Plug	1	701988	108A	Bracket Ring	1	834018
82	Spacer Ring	2	374011	108B	Bracket Stud	6	921534
101	Gear	1	See Table	108C	Lockwasher	10	909630
102	Pinion & Shaft	1	See Table	108D	Nut (1/2 – 13)	10	922850
104	Oil Seal	1	331930	108E	Torque Arm (Stud)	1	921584
104A	Oil Seal	1	331909	108F	Eyebolt	1	922474
110	Gearbox Assembly ¹	1	894011	108G	Plain Washers (1/2")	3	909670
111	Gasket – Cover	1	814010	108H	Nut (3/8 – 24)	6	922843
112	Capscrews – Cover	12	920381	108K	Setscrew	6	922204
114	Closure Plate – Input	1	*	108L	Mounting Bracket	1	834031
115	Gasket – Input Closure Plate	1	814011	108M	Slider Post	2	834030
116	Capscrews – Closure Plate	12	920073	108N	Foot	1	834028
119	Closure Plate – Blind	1	*	108P	Pipe Cap	2	344001
119A	Gasket – Blind Closure Plate	1	814012				

*Non-saleable item – included with Gearbox Assembly. Keep this parts list with Installation, Operation and Maintenance Instructions.

¹Gearbox Assembly includes Ref. Nos. 38, 110, 111, 112, 114, 115, 116, 119, 119A.

GEAR AND PINION SELECTION TABLE

RATIO	RPM	102 PINION NO.	QTY.	101 GEAR NO.	QTY.
2.70	640	915148	1	919948	1
3.52	500	915134	1	919934	1
4.36	400	915135	1	919935	1
5.77	300	915136	1	919936	1
7.71	230	915137	1	919937	1
9.18	190	915149	1	919949	1

NOTE: Speed is based on 1750 rpm input.

INSTALLATION

NOTICE

This product must only be installed in systems which have been designed by those qualified to engineer such systems. The system must be in accordance with all applicable regulations and safety codes and warn of any hazards unique to the particular system.

ALIGNMENT ADJUSTMENT

The gear reducer can be moved vertically on its bracket mount to raise or lower the output shaft (slow speed shaft) to align with the pump shaft.

The reducer can also be rotated on the bracket ring to facilitate both horizontal and vertical alignment of the input shaft (high speed shaft) to the motor shaft. This flexibility in movement eliminates the need for shims under the motor or driver in most cases. NOTE: Refer to Blackmer Dimensions 109-103 for maximum variation of shaft alignment to maintain proper gear reducer lubrication.

Follow these steps to align the reducer:

1. Align the output shaft to the pump shaft by loosening the four (4) setscrews (108K) and locknuts in the mounting bracket (108L), enabling the reducer to slide freely on the slider posts.
2. Once the proper alignment is determined, retighten the setscrews and locknuts. Leave the torque arm locknuts loosened for the next step.
3. Align the input shaft to the motor shaft by loosening the four (4) bracket nuts (108D) in the bracket ring (108A) enabling the reducer to rotate freely. If the reducer sticks on the mounting bracket, tap it lightly with a mallet.
4. After obtaining the correct alignment, be sure to retighten the bracket nuts and the upper and lower locknuts of the torque arm.

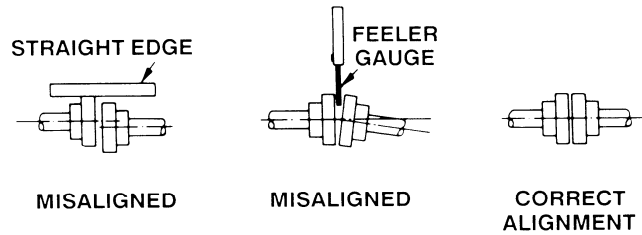

Figure 1 - Alignment Check

COUPLING ALIGNMENT

Both angular and parallel coupling alignment MUST be maintained between the pump, gear, motor, etc. in accordance with manufacturer's instructions. Verify coupling alignment after installation of new or rebuilt pumps. See fig. 1.

1. Parallel alignment: The use of a laser alignment tool or dial indicator is preferred. If a laser alignment tool or dial indicator is not available, use a straightedge. Turn both shafts by hand, checking the reading through one complete revolution. Maximum offset must be less than .005" (125 microns).
2. Angular alignment: Insert a feeler gauge between the coupling halves. Check the spacing at 90° increments around the coupling (four check points). Maximum variation must not exceed .005" (125 microns). Some laser alignment tools will check angular alignment as well.
3. Replace the coupling guards after setting alignment.

MAINTENANCE

NOTICE:

Maintenance and troubleshooting must be done by an individual experienced with pump and reducer maintenance and the type of system involved.

NOTICE:

To avoid possible entanglement in moving parts do not lubricate pump bearings, gear reducer or any other parts while the pump is running.

CAUTION: The normal full load operating temperature of the gearcase is 180°F (82°C) – too hot to touch with the bare hand.

LUBRICATION

Gear reducers are not lubricated at the factory. Oil MUST be added before starting the pump.

Horsepower calculations for Blackmer reducers are based on 75°F (24°C) ambient air temperature; 200°F (93°C) maximum oil temperature using synthetic oil.

Blackmer recommends using synthetic oil with oxidation inhibitors and is compatible with Buna elastomers. Use synthetic oil AGMA Viscosity Grade 4 or ISO Viscosity Grade 150 such as Mobil SHC 629, Shell Omala S4 GX 150, Castrol Isolube EP 150 or equivalent.

To add oil to the gear reducer:

1. Remove the oil level plug (29) and the fill and vent plug (76C). **NOTE:** The vent fitting in the fill plug (76C) should be kept clean to prevent expansion from forcing oil leaks at the shaft.

2. Add oil through the filler hole until oil runs out of the oil level hole – approximately 1.25 qt. (1.18 l) depending on the orientation of the reducer mounting.
3. Replace the oil level plug and the fill and vent plug.
4. After the first two weeks of operation, the oil should be drained, the gearcase flushed, and new oil added.

For normal operation, the oil should be changed every six months or 1000 hours, whichever is shorter. If operation is accompanied by frequent and wide changes in temperature, or if the unit operates in an unusually moist or dusty atmosphere, the oil should be changed every 500 hours or every three months. **NOTE:** To maintain proper gear reducer lubrication, refer to Blackmer Dimensions 109-103 for maximum variation of shaft alignment.

REDUCER DISASSEMBLY

The gearcase on the bracket mounted gear reducer can usually be removed from its bracket without disturbing the motor or pump mounting.

1. Take apart the couplings and remove the six bracket nuts (108D) and lockwashers (108C) from the bracket ring. Also remove the upper locknut and lockwasher from the torque arm (108E).
2. Once the bracket nuts are removed, rotate the gearcase on the bracket and swing the input shaft away from the motor.
3. The gear reducer can then be lifted off the pump with the bracket ring and studs still intact.

4. Remove the twelve hex-head cover capscrews (112).
NOTE: The gearcase cover is located on the gearcase with two (2) dowel pins (38). These pins remain in the gearcase.
 5. After the capscrews have been removed, insert a wedge between the projecting lugs on the gearcase cover and tap lightly until the cover loosens and can be removed from the casing.
 6. Remove the cover gasket (111).
 7. The pinion & shaft (input shaft) (102) is a one-piece assembly and does not come apart. If necessary, the bearings (24A) can be removed from the shaft with the use of a bearing puller or arbor press.
 8. To remove the gear (101) and bearings (24) from the output shaft (125), use a gear puller or arbor press. Support the assembly on the gear and press the shaft out of the gear and one bearing only. The second bearing must come off in the other direction because of the shoulder on the shaft.
- b. Apply a coat of graphite, molysulphide, or white lead to the shaft.
 - c. Press the short end of the shaft (125) squarely into the bearing (24), and install the spacer ring (82).
 - d. Align the gear key (124) with the notch in the gear, and press the gear (101) squarely onto the shaft.
 - e. Add a spacer ring (82) and press the second bearing (24) onto the shaft.
2. Prior to installing the bearings, follow steps 1a and 1b. To assemble the input shaft (102) (Pinion & Shaft), press a bearing (24A) onto each end of the shaft.
 3. After the shafts, gears and bearings have been assembled, apply a light film of oil in the bearing bores of the gearcase to help the bearings slide into position.
 4. If the oil seal (104) has been removed from the gearcase, it must be replaced prior to reassembly. Refer to step 2 of "Oil Seal Replacement."
 5. To install the shaft assemblies into the gearcase it is easiest to tip the gearcase so that it is resting on the bracket studs with the cavity opening upward.
 - a. Start the output shaft (125) into the bearing bore of the gearcase.
 - b. Align the bearings and gear teeth of the input shaft (102) with the output shaft and drop the two shaft assemblies together into their respective bearing bores.

NOTE: It is important to line the bearings up squarely with the bores in order for them to drop smoothly into place. If the bearings are positioned correctly in the gearcase, the shafts should rotate freely when turned by hand.

OIL SEAL REPLACEMENT

1. To replace the oil seal (104A) on the input shaft, it is only necessary to remove the closure plate (114). Once the plate is removed, the old seal can be pressed out and a new one installed. Grease the lip of the oil seal before installing. The oil seal must be inserted such that the lip of the seal will face inward when the closure plate is reattached to the gearcase cover.
2. To replace the oil seal (104) on the output shaft, it is necessary to disassemble the body and cover assembly and remove the output shaft. (Refer to "Reducer Disassembly.") Grease the lip of the oil seal and insert it into the bearing bore of the gearcase so that the lip of the seal faces inward.

REDUCER ASSEMBLY

Before reassembling the gear reducer, clean each part thoroughly. Wash out the bearing bores and remove all burrs or sharp corners with a file.

NOTE: Disregard steps 1 and 2 if the shaft and bearing assemblies have not been dismantled.

1. The output shaft (125) has a stepped shoulder where the gear must be located.
 - a. Before installing the gear and bearings, remove all dirt, burrs, or sharp corners from the shaft to prevent galling or seizing of the gear and shaft.

6. Once the input and output shaft assemblies are properly installed, set the cover gasket (111) on the gearcase.
7. Position the cover on the gearcase using the dowel pins for alignment.
8. Install and tighten the cover capscrews (112).
9. Make sure the oil seal (104A) is inserted in the closure plate (114) before reattaching the plate to the gearcase cover. Refer to step 1 of "Oil Seal Replacement."
10. Attach the closure plate gasket (115) and the closure plate (114) to the gearcase cover

TROUBLESHOOTING

NOISE AND VIBRATION

POSSIBLE CAUSES:

1. Worn or damaged bearings.
2. Inadequate lubrication / use of wrong lubricant.
3. Impurities in the lubricant, such as abrasive particles.
4. Excessive overloading.
5. Misalignment to either pump or motor.

REMEDY:

- Replace bearings.
- Check oil condition. The lubricant may not be getting to the contact areas of the gear teeth, or the viscosity of the oil may be too low for the operating temperature (see "Lubrication").
- Replace with clean oil (see "Lubrication")
- Overloading causes overheating which may lower oil viscosity and thus cause the oil film on gear teeth contact surfaces to break down. The gears will begin to "groan" as the oil loses its effectiveness. If the loading is not decreased, the gear teeth will begin to "bite" into each other and wear out rapidly.
- Recheck alignment and adjust as necessary.

