

BLACKMER PARTS LIST

PUMP MODEL: PV6A, PV8A

Discontinued Models - Parts Availability may be limited.
 (See Instructions 111-A00 for Installation, Operation and Maintenance)

965805
 Page 1 of 2

PARTS LIST
111-A01

Section 111
 Effective Apr 2005
 Replaces Mar 2005

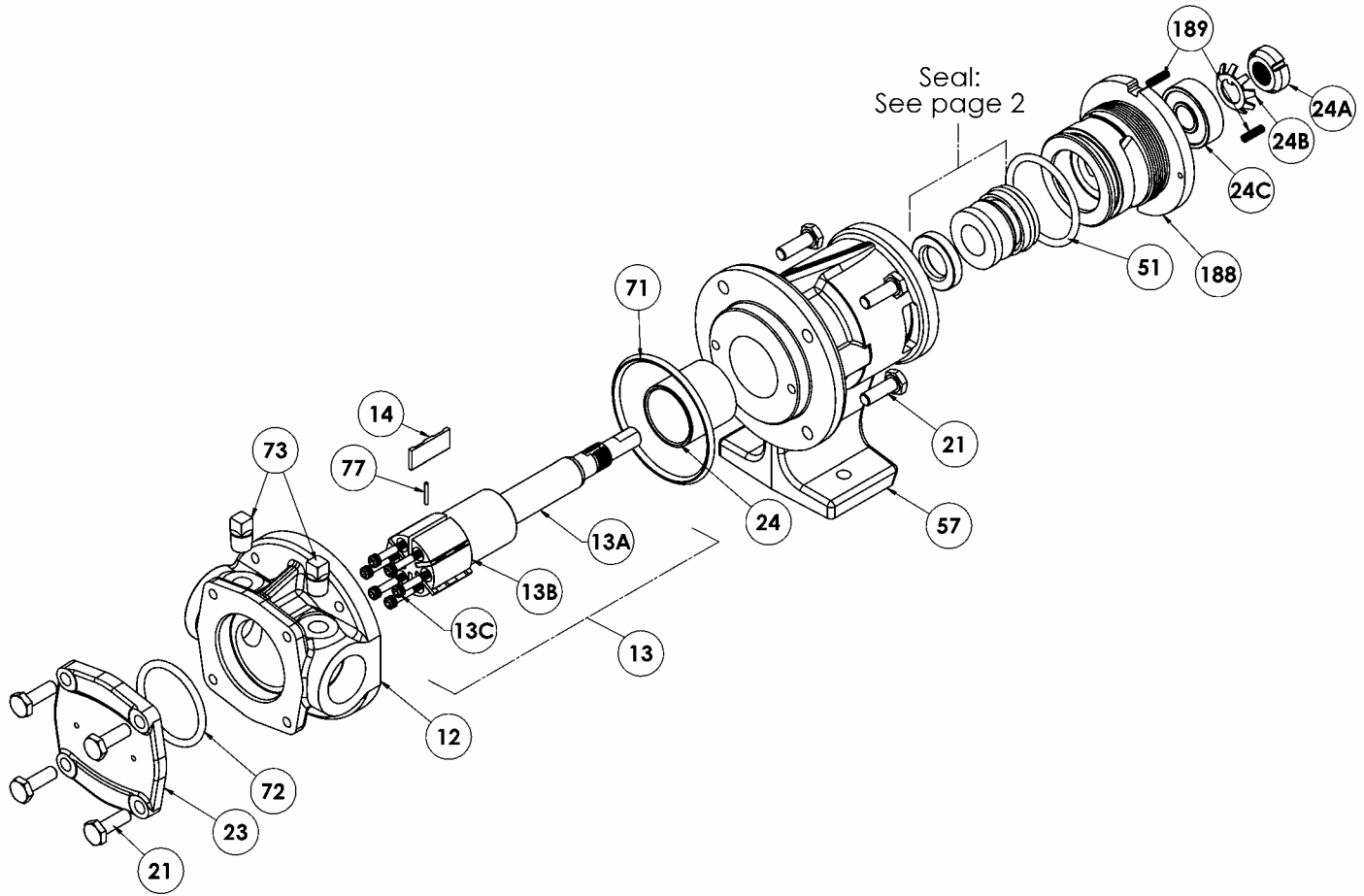

Ref. No.	Description	Parts per Pump	Part No.	Ref. No.	Description	Parts per Pump	Part No.
12	Cylinder – PV6A	1	026805	24A	Locknut	1	903572
	Cylinder – PV8A		026806	24B	Lock washer	1	903573
13	Rotor & Shaft Asy. (Std.) ¹	1	266805	24C	Bearing – Ball	1	903188
	Rotor & Shaft Asy. (E.C.) ²		266806	51	O-Ring – Bearing Adjuster (FKM)	1	702205
13A	Shaft	1	216805	57	Drive Housing	1	836805
13B	Rotor (Std.) ¹	1	206805	71	O-Ring – Drive Housing (FKM)	1	702015
	Rotor (E.C.) ²		206806	72	O-Ring – Head (FKM)	1	701973
13C	Rotor Cap screws	6	920267	73	Plug – 1/8" NPT	2	908185
14	Vane – Duravane (Std.) ¹	6	094861	77	Push Rod – PV6A – Plastic (Std.) ¹	3	125811
	Vane – Bronze ²		094871		Push Rod – PV6A – Steel ²		126805
21	Cap screw – Head	8	920073		Push Rod – PV8A – Plastic (Std.) ¹		125812
23	Head	1	036805		Push Rod – PV8A – Steel ²		126806
24	Bearing – Sleeve	1	166805	188	Bearing Adjuster	1	306805
				189	Bearing Adjuster Set Screw	2	922024

¹ Standard Clearance Rotor, Duravanes, Plastic Push Rods and the Mechanical Seal must be used together.

² Extra Clearance Rotor, Bronze Vanes, Metal Push Rods and the Lip Seal must be used together. (for higher viscosity applications).
 Keep this parts list with Installation, Operation and Maintenance Instructions.

MECHANICAL SEAL

Ref. No.	Part Name	Parts Per Pump	Part No.
153	Mechanical Seal Complete Includes 153A and 153B	1	336805
153A	Stationary Seal and Seat	-	**
153B	Rotating Face & Element	-	**
153C	Seal Spacer	1	336806

** 153A and 153B are not available separately.

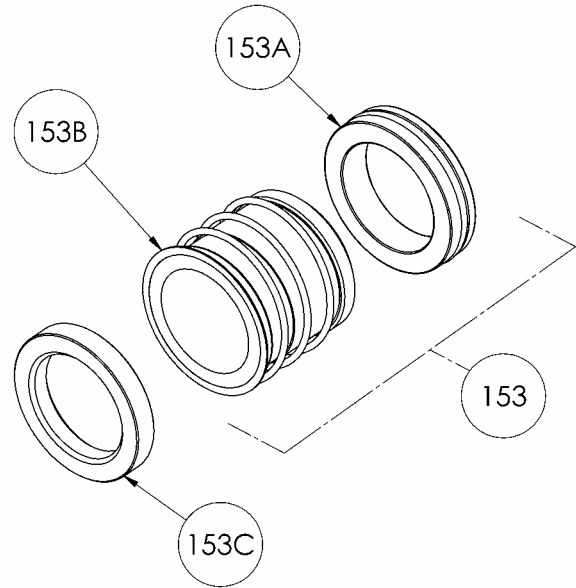

1809 Century Avenue, Grand Rapids, Michigan 49503-1530, U.S.A.
Telephone: (616) 241-1611 / Fax: (616) 241-3752
E-Mail: blackmer@blackmer.com / Internet: www.blackmer.com

Parts List 111-A01
Page 2 of 2