

# BLACKMER PARTS LIST

## PUMP MODEL: ATX300-HYD

(See Instructions 201A-A00 for Installation, Operation and Maintenance)

Section 200  
Effective July 2002  
Replaces June 2002

**DISCONTINUED MODEL  
PARTS AVAILABILITY  
MAY BE LIMITED**

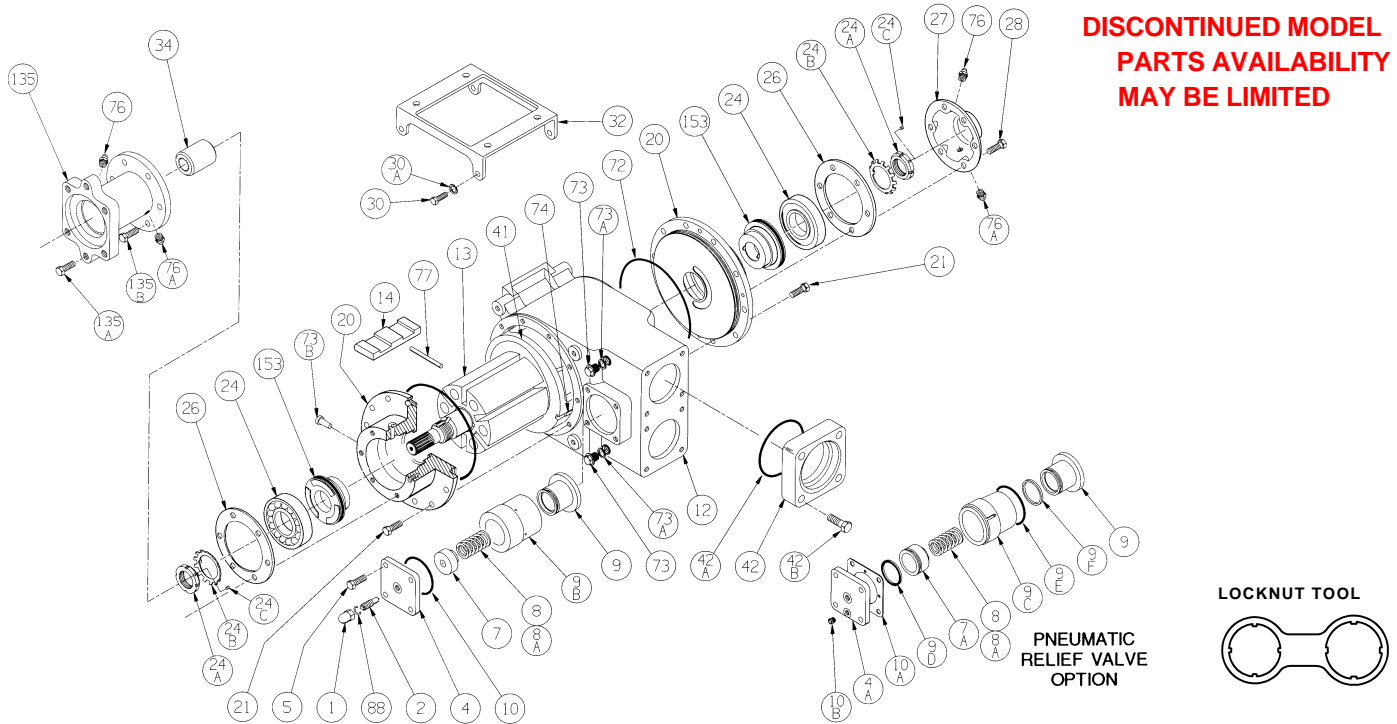

Ref No.	Description	Parts per Pump	Part no.	Ref No.	Description	Parts per Pump	Part No.
1	Cap – R/V (Std)	1	411452	26	Gasket – Bearing Cover	2	385125
2	Adjusting Screw – R/V (Std)	1	431800	27	Bearing Cover – Outboard	0 - 1	042227
4	Cover – R/V (Std)*	1	411800	28	Capscrews – Bearing Cover	6 - 12	920127
4A	Cover – R/V (AIR)		411801	30	Capscrews – Mounting Bracket	4	924064
5	Capscrews – R/V Cover (Std, AIR)	4	920199	30A	Lockwasher – Bracket Capscrews	4	909586
7	Spring Guide – R/V (Std)*	1	425101	32	Mounting Bracket	1	831800
7A	Spring Guide – R/V (AIR)		425102	34	Coupling	1	906073
8	Spring - R/V (3.9-5.2 bar) (Std, AIR) <sup>1</sup>	1	471621	41	Liner – ATX300	1	181803
8A	Spring - R/V (5.24-8.6 bar)* (Std, AIR) <sup>2</sup>		471614	42	Flange – 80mm Weld (Aluminum)	0 - 2	651820
9	Valve – R/V (Std, AIR)	1	455104		Flange – 80mm Weld (Cast Steel)		651819
9B	Valve Guide – R/V (Std)*	1	425103	42A	O-Ring – Flange (Buna-N)	0 - 2	702002
9C	Valve Guide – R/V (AIR)		425104		O-Ring – Flange (PTFE)		702080
9D	Seal – Spring Guide (AIR)	0 - 1	495025	42B	Capscrews – Flange	0 - 8	924086
9E	O-Ring – Valve Guide (AIR) (Buna-N)	0 - 1	701939	72	O-Ring – Head (Buna-N)*	2	702122
9F	Seal – Valve (AIR)	0 - 1	495023		O-Ring – Head (PTFE)	2	702235
10	O-Ring – R/V Cover (Std) (Buna-N)*	1	702014	73	Gage Plug	2	908191
	O-Ring – R/V Cover (Std) (PTFE)		702224	73A	Gasket – Gage Plug	2	381818
10A	Gasket – R/V Cover (AIR)	0 - 1	537300	73B	Plug – Weep Hole	4	340000
10B	Breather Vent – R/V Cover (AIR)	0 - 1	495024	74	Key – Liner	1	185191
12	Casing	1	011800	76	Grease Fitting	2	317815
13	Rotor & Shaft (Splined)	1	261872	76A	Grease Relief Fitting	2	701992
14	Vane – Duravane	6	094500	77	Push Rod – ATX300	3	121810
20	Head	2	031826	88	Gasket – R/V Cap	1	701981
21	Capscrews – Head	20	920199	135	Hydraulic Motor Adapter	1	041802
24	Ball Bearing	2	903172	135A	Capscrews – Motor/Adapter	2	920471
24A	Locknut – Ball Bearing	2	903582	135B	Capscrews – Adapter	6	920199
24B	Lockwasher – Ball Bearing	2	903524		Hydraulic Motor	0-1	889611
24C	Setscrew – Locknut	2	924060		Tool - Locknut		903091

<sup>1</sup> For Pneumatic Relief Valve (AIR), spring p/n 471621 is 5.2 bar (75 psi) and non-adjustable.

<sup>2</sup> For Pneumatic Relief Valve (AIR), spring p/n 471614 is 7.9 bar (115 psi) and non-adjustable.

STD = Standard Direct Acting Relief Valve.  
AIR = Optional Pneumatic Actuated Relief Valve.  
\* = Standard on pump.

Keep this parts list should be kept with Installation, Operation and Maintenance Instructions.

**MECHANICAL SEAL - OPTIONAL**

Ref. No.	Description	Parts Per Pump	Part No.
153	Mechanical Seal Complete - Cast Iron Stationary Seat, Carbon Seal Face, Buna-N O-Rings. *	2	331880
	Mechanical Seal Complete - Cast Iron Stationary Seat, PTFE O-Ring, Carbon Seal Face w/ PTFE Seal Ring.		331873
153D	O-Ring - Stationary (Buna-N)	2	701936
	O-Ring - Stationary (PTFE)		702080
153L	O-Ring - Rotating (Buna-N)	2	711912
	Seal Ring - Rotating (PTFE)		**

\* Standard on pump

\*\* PTFE Rotating Seal Ring is not available as a separate part.

