

# BLACKMER TRUCK PUMPS

960300

## INSTRUCTIONS NO. 285/G

### INSTALLATION, OPERATION, AND MAINTENANCE INSTRUCTIONS

#### MODEL: STNP3A

#### and Discontinued STNP3 Model

Section	200
Effective	December 1995
Replaces	March 1971

### SAFETY DATA



**This is a SAFETY ALERT SYMBOL.**

When you see this symbol on the product, or in the manual, look for one of the following signal words and be alert to the potential for personal injury, death or major property damage.

**▲ DANGER**

Warns of hazards that **WILL** cause serious personal injury, death or major property damage.

**▲ WARNING**

Warns of hazards that **CAN** cause serious personal injury, death or major property damage.

**▲ CAUTION**

Warns of hazards that **CAN** cause personal injury or property damage.

**NOTICE:**

Indicates special instructions which are very important and must be followed.

**NOTICE:**

Blackmer truck pumps **MUST** only be installed in systems which have been designed by qualified engineering personnel. The system **MUST** conform to all applicable local and national regulations and safety standards.

This manual is intended to assist in the installation and operation of Blackmer STNP truck pumps, and **MUST** be kept with the pump.

Blackmer truck pump service shall be performed by qualified technicians **ONLY**. Service shall conform to all applicable local and national regulations and safety standards.

Thoroughly review this manual, all instructions and hazard warnings, **BEFORE** performing any work on Blackmer STNP truck pumps.

Maintain **ALL** system and Blackmer truck pump operation and hazard warning decals.

**▲ WARNING**



Hazardous machinery can cause severe personal injury or property damage.

**FAILURE TO SET THE VEHICLE EMERGENCY BRAKE AND CHOCK WHEELS BEFORE PERFORMING SERVICE CAN CAUSE SEVERE PERSONAL INJURY OR PROPERTY DAMAGE.**

### TABLE OF CONTENTS

Page

<b>PUMP DATA</b> .....	2
Technical Data.....	2
Initial Start Up Information.....	2
<b>INSTALLATION</b> .....	2
Pre-Installation Cleaning.....	2
Location and Piping.....	2
Truck Mounting.....	2
Pump Drive.....	2
Pump Rotation.....	3
<b>OPERATION</b> .....	3
Pre-Start Up Check List.....	3
Start Up Procedures.....	3
Pump Speed.....	3
Reverse Rotation.....	3
Flushing the Pump.....	4
Relief Valve.....	4
Relief Valve Setting and Adjustment.....	4
<b>MAINTENANCE</b> .....	4
Lubrication.....	4
Vane Replacement.....	4
Pump Disassembly.....	5
Pump Assembly.....	5
<b>GENERAL PUMP TROUBLESHOOTING</b> .....	7-8

**NOTE:** Numbers in parentheses following individual parts indicate reference numbers on the corresponding Blackmer Parts List 285/G1.

### SAFETY DATA

**▲ WARNING**



Hazardous or toxic fluids can cause serious injury.

**IF PUMPING HAZARDOUS FLUIDS SYSTEM MUST BE FLUSHED PRIOR TO PERFORMING SERVICE.**

**▲ WARNING**



Hazardous machinery can cause severe personal injury.

**FAILURE TO STOP THE PUMP BEFORE ADJUSTING THE SHAFT PACKING CAN CAUSE SEVERE PERSONAL INJURY.**

**▲ CAUTION**



Hazardous pressure can cause personal injury or property damage.

**FAILURE TO RELIEVE SYSTEM PRESSURE PRIOR TO PERFORMING PUMP SERVICE OR MAINTENANCE CAN CAUSE PERSONAL INJURY OR PROPERTY DAMAGE.**

# PUMP DATA

## TECHNICAL DATA

Maximum Temperature*	350°F (176°C)
Maximum Pump Speed	640 RPM
Maximum Viscosity*	40,000 SSU (8,500 cSt)
Maximum Differential Pressure	150 psi (1034 kPa)
Maximum Working Pressure (Inlet Pressure + Differential Pressure)	175 psi (1207 kPa)

\* Optional materials of construction may be required to meet the operating limits listed above. Refer to Blackmer Material Specs 203/91-92.

## INITIAL START UP INFORMATION

Model No. \_\_\_\_\_

Serial No. \_\_\_\_\_

Date of Installation: \_\_\_\_\_

Pressure Gauge Reading: \_\_\_\_\_

Vacuum Gauge Reading: \_\_\_\_\_

Flow Rate: \_\_\_\_\_

## INSTALLATION

### NOTICE:

**BLACKMER TRUCK PUMPS MUST ONLY BE INSTALLED IN SYSTEMS DESIGNED BY QUALIFIED ENGINEERING PERSONNEL. SYSTEM DESIGN MUST CONFORM WITH ALL APPLICABLE REGULATIONS AND CODES AND PROVIDE WARNING OF ALL SYSTEM HAZARDS.**



**FAILURE TO SET THE VEHICLE EMERGENCY BRAKE AND CHOCK WHEELS BEFORE PERFORMING SERVICE CAN CAUSE SEVERE PERSONAL INJURY OR PROPERTY DAMAGE.**

### PRE-INSTALLATION CLEANING

Foreign matter entering the pump WILL cause extensive damage. The supply tank and intake piping MUST be cleaned and flushed prior to pump installation and operation.

### LOCATION AND PIPING

An improperly designed piping system or unit installation WILL significantly reduce pump performance and life. Blackmer recommends the following piping system layout and unit installation.

1. To minimize intake losses, locate the pump as close as possible to the source of supply.
2. Piping MUST be properly supported to prevent any piping loads from being placed on the pump.
3. Intake piping and fittings MUST be at least as large in diameter as the pump intake connection.
4. Minimize the number of intake line fittings (valves, elbows, etc.) and piping turns or bends.
5. Temporarily install vacuum and pressure gauges in the 1/4" NPT intake and discharge ports located on the pump cylinder to check pump at start-up.

6. Install a strainer in the inlet line to protect the pump from foreign matter. Placement of intake strainers should facilitate frequent cleaning.
7. Intake and discharge piping MUST be free of all leaks.

### TRUCK MOUNTING

The pump will operate satisfactorily in any position. The pump can be bolted to the truck frame or on a saddle hung below the frame, and MUST be adequately supported. Mounting the pump with the cylinder feet down, or with the intake port up, is recommended for thorough draining of the pump.

### PUMP DRIVE

The pump may be driven by a power take-off through universal joints. When using universal joints, a splined slip joint, properly lubricated, must be used on the connecting jack shaft to prevent end thrust on the pump shaft.

It is very important to install a proper drive line to avoid excessive wear, vibration and noise (see Fig. 1 and Table 1).

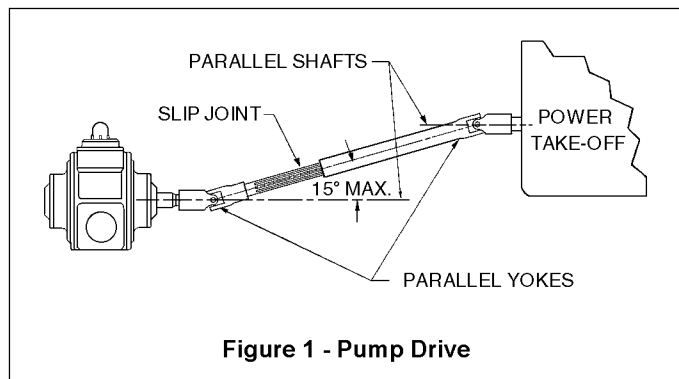

Angle of Drive Shaft		
1° through 5°	6° through 10°	11° through 15°
Very Good	Good	Fair

Table 1

# INSTALLATION

## General guidelines to follow for proper pump drive:

1. Square slip joints are not recommended.
2. Use the least number of jack shafts as is practical.
3. Use an even number of universal joints.
4. The pump shaft and power take-off shaft should be parallel in all respects. It is recommended that an angular level measuring device be used to ensure the PTO and pump shaft are parallel to each other. If necessary, the pump can be shimmed to correct any misalignment. The PTO shaft coming off at the transmission does not need to be perfectly horizontal as long as the pump is shimmed to have its shaft parallel in all respects to the PTO shaft.
5. The yokes of the universals at both ends of the jack shaft should be parallel.
6. The maximum recommended angle between the jack shaft and the pump shaft is 15 degrees. Refer to Table 1.

Failure to follow any of these guidelines may result in a gallop or uneven turning of the pump rotor, which will in turn cause a surging vibration to the liquid stream and piping system. Contact the supplier of the drive line components for specific design assistance.

## Hydraulic Drive

The pump may also be driven hydraulically. Hydraulic motors should be well supported with their shafts parallel to the pump shaft in all respects.

## PUMP ROTATION

The STNP3A pump model is designed as right hand pump only, with CLOCKWISE rotation. When viewing the pump from the drive end, the pump intake port must be on the right.

### NOTICE:

**CONFIRM CORRECT PUMP ROTATION BY CHECKING THE PUMP ROTATION ARROWS RESPECTIVE TO PUMP DRIVER ROTATION.**

---

# OPERATION

## PRE-START UP CHECK LIST

1. Check the alignment of the pipes to the pump. Pipes should be supported so that they do not spring away or drop down when the pump flanges or union joints are disconnected.
2. Temporarily install vacuum and pressure gauges in the 1/4" NPT ports located on the pump cylinder. These can be used to check the actual suction and discharge conditions after pump start-up.
3. Inspect complete piping system to ensure that no piping loads are being placed on the pump.
4. Secure appropriate hose connections.

3. Inspect piping, fittings, and associated system equipment for leaks, noise, vibration and overheating.
4. If possible, check the flow rate to ensure the pump is operating within the expected parameters.
5. Check the pressure setting of the relief valve by momentarily closing a valve in the discharge line and reading the pressure gauge. This pressure should be 15 - 20 psi (103 - 138 kPa) higher than the maximum system operating pressure, or the external bypass valve setting (if equipped). **DO NOT operate the pump against a closed discharge valve for more than 15 seconds.** If adjustments need to be made, refer to the "Relief Valve Setting and Adjustment" section of this manual.

## START UP PROCEDURES

### NOTICE:

**CONSULT THE "GENERAL PUMP TROUBLESHOOTING" SECTION OF THIS MANUAL IF DIFFICULTIES DURING START UP ARE EXPERIENCED.**

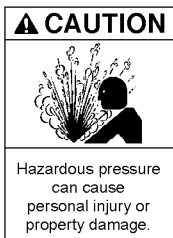

**PUMP OPERATING AGAINST A CLOSED VALVE CAN CAUSE SYSTEM COMPONENT FAILURE, PERSONAL INJURY AND PROPERTY DAMAGE.**

1. Start the pump. Priming should occur within one minute.
2. Check the vacuum and pressure gauges to ensure the system is operating within expected parameters. Record the gauge readings in the "Initial Start Up Information" section of this manual for future reference.

## PUMP SPEED

PTO and hydraulically driven units **MUST** contain speed control devices to prevent pump speeds above the maximum RPM specifications, regardless of the truck engine unloading speeds. Should fluid delivery be appreciably less than expected, see the "General Pump Troubleshooting" section.

## REVERSE ROTATION

### NOTICE:

**A SEPARATE PRESSURE RELIEF VALVE MUST BE INSTALLED WHEN OPERATING THE PUMP IN REVERSE TO PROTECT THE PUMP FROM EXCESSIVE PRESSURE.**

It may be desirable to run the pump in reverse rotation for system maintenance. The pump will operate satisfactorily in reverse rotation for a LIMITED time, at a reduced performance level. When operating the pump in reverse, a separate bypass valve **MUST** be installed to protect the pump from excessive pressure.

# OPERATION

## FLUSHING THE PUMP

### NOTICE:

IF FLUSHING FLUID IS TO BE LEFT IN THE PUMP FOR AN EXTENDED TIME, IT MUST BE A LUBRICATING, NON-CORROSIVE FLUID. IF A CORROSIVE, NON-LUBRICATING FLUID IS USED, IT MUST BE FLUSHED FROM THE PUMP IMMEDIATELY.

To flush the pump, use the following procedure:

1. Allow the pump to evacuate as much fluid as possible.
2. Run cleaning fluid through the pump intake. The cleaning fluid should be compatible with the pump seal rings and vane material. When handling "sticky" fluids that solidify within the pump (i.e., waxes, adhesives, resins, asphalts, etc.), use a fluid that will prevent solidification of the fluid being transferred and facilitate flushing.
3. Operate the pump against a closed discharge for 15 seconds to allow the cleaning fluid to recirculate through the internal relief valve.

## RELIEF VALVE

### NOTICE:

THE PUMP INTERNAL RELIEF VALVE IS DESIGNED TO PROTECT THE PUMP FROM EXCESSIVE PRESSURE AND MUST NOT BE USED AS A SYSTEM PRESSURE CONTROL VALVE.

Pumping volatile liquids under suction lift may cause cavitation. Partial closing of the discharge valve WILL result in internal relief valve chatter and is NOT recommended. For these applications, install an external bypass valve, and any

necessary piping, back to the storage tank. This bypass system is also recommended when operating for extended periods (more than 1 minute) against a closed discharge valve.

## RELIEF VALVE SETTING AND ADJUSTMENT

The relief valve pressure setting is marked on a metal tag attached to the valve cover. Generally, the relief valve should be set at least 15 - 20 psi (103-138 kPa) higher than the operating pressure, or the external bypass valve setting (if equipped).

1. To **INCREASE the pressure setting**, remove the relief valve cap (1) and turn the adjusting screw (2) *inward*, or **CLOCKWISE**. Replace the valve cap.
2. To **DECREASE the pressure setting**, remove the relief valve cap (1) and turn the adjusting screw (2) *outward*, or **COUNTERCLOCKWISE**. Replace the valve cap.

### CAUTION

Hazardous Pressure

INCORRECT SETTINGS OF THE PRESSURE RELIEF VALVE CAN CAUSE SYSTEM COMPONENT FAILURE, PERSONAL INJURY AND PROPERTY DAMAGE.

Refer to Blackmer Pump Parts List 285/G1 for various relief valve spring pressure ranges. The pumps are supplied from the factory with the relief valve adjusted to the mid-point of the spring range.

# MAINTENANCE



FAILURE TO SET THE VEHICLE EMERGENCY BRAKE AND CHOCK WHEELS BEFORE PERFORMING SERVICE CAN CAUSE SEVERE PERSONAL INJURY OR PROPERTY DAMAGE.

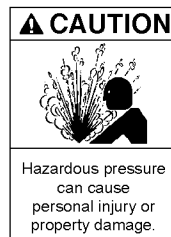

FAILURE TO RELIEVE SYSTEM PRESSURE PRIOR TO PERFORMING PUMP SERVICE OR MAINTENANCE CAN CAUSE PERSONAL INJURY OR PROPERTY DAMAGE.



IF PUMPING HAZARDOUS FLUIDS SYSTEM MUST BE FLUSHED PRIOR TO PERFORMING SERVICE.



FAILURE TO STOP THE PUMP BEFORE ADJUSTING THE SHAFT PACKING CAN CAUSE SEVERE PERSONAL INJURY.

### NOTICE:

MAINTENANCE SHALL BE PERFORMED BY QUALIFIED TECHNICIANS ONLY, FOLLOWING THE APPROPRIATE PROCEDURES AND WARNINGS AS PRESENTED IN THIS MANUAL.

## LUBRICATION

Sleeve bearings (bushings) are lubricated by the liquid being pumped. Additional lubrication is not required.

## VANE REPLACEMENT

1. Remove the head assembly from the **outboard** (non-driven) side of the pump according to steps 4 - 6 in the "Pump Disassembly" section of this manual.

# MAINTENANCE

2. Turn the shaft by hand until a vane comes to the top (12 o'clock) position of the rotor. Remove the vane.
3. Install a new vane, ensuring that the rounded edge is UP, and the relief grooves are facing TOWARDS the direction of rotation. See Figure 2.
4. Repeat steps 2 and 3 until all vanes have been replaced.
5. Reassemble the pump according to steps 2 through 7 of the "Pump Assembly" section of this manual.

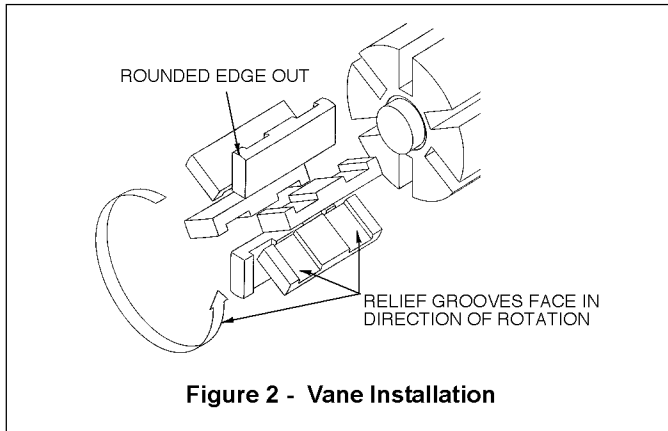

Figure 2 - Vane Installation

## PUMP DISASSEMBLY

### NOTICE:

FOLLOW ALL HAZARD WARNINGS AND INSTRUCTIONS PROVIDED IN THE "MAINTENANCE" SECTION OF THIS MANUAL.

1. Starting on the **inboard** (driven) end of the pump, clean the pump shaft thoroughly, making sure the shaft is free of nicks and burrs. This will prevent damage to the packing or mechanical seal when the inboard head assembly is removed.
2. The STNP3A pump model is equipped with a shaft support bearing. **To remove the shaft support bearing:**
  - a. Remove the bearing flange capscrews (106D) and the bearing flange cover (106C).
  - b. Loosen the setscrew in the lock collar (106B).
  - c. Using a punch tool and hammer, tap the bearing lock collar in the opposite direction of pump rotation. See Figure 3.

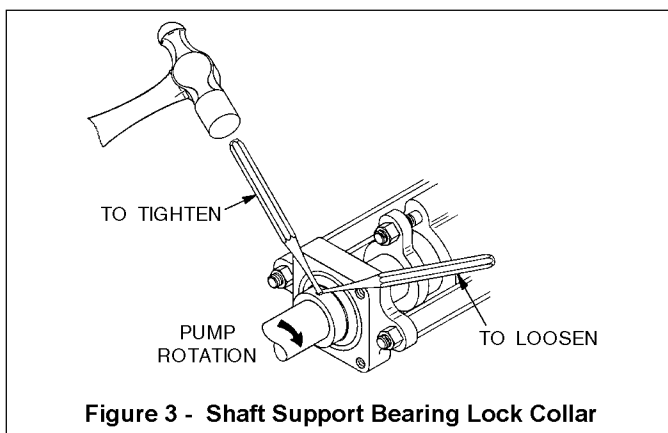

Figure 3 - Shaft Support Bearing Lock Collar

- d. Once the collar is loosened, remove the bearing and collar assembly (106B) from the shaft
  - e. Remove the locknuts (106A) from the hex flange rods and remove the bearing flange (106).
2. **If equipped with packing:**
    - a. Remove the packing follower stud nuts (18) and pull the packing follower (75) out of the stuffing box. A slight pry may be necessary.
    - b. pull the packing rings (19) from the stuffing box with a packing removal tool. Use care not to damage the shaft. Discard the packing.
    - c. Remove the pack washer (58) from the stuffing box.
  3. **If equipped with a commercial mechanical seal:**
    - a. Remove the 1/8" pipe plug (73A) from the stuffing box in the head and loosen all mechanical seal set screws with an allen wrench.
    - b. Remove the seal retainer stud nuts (18) and remove the seal retainer (126) from the head.
    - c. The mechanical seal assembly (153) and seal spacer (82) can be pulled from the stuffing box after the head is removed in step 4.
  4. Remove the head capscrews (21) and pry the head assembly (20) away from the cylinder. The disc (71), head seal ring (72), and mechanical seal (if equipped) will come off with the head. Use care not to drop and damage these components when pulling the head off the shaft
  5. Remove the disc (71) and head seal ring (72) from the head assembly. Discard the head seal ring.
  6. The sleeve bearing (24) is press fit into the head and does not need to be removed unless replacement is necessary. See step 2 of the "Pump Assembly" section.
  7. Gently Pull the rotor and shaft (13) from the cylinder. While one hand is pulling the shaft, the other hand should be cupped underneath the rotor to prevent the vanes (14) and push rods (77) from falling out. Carefully set the rotor and shaft aside for future vane replacement and reassembly.
  8. From the opposite (outboard) side of the pump, remove the bearing cover capscrews (28), bearing cover (27) and bearing cover seal ring (26). Discard the seal ring (26).
  9. Remove the outboard head (23), disc (71) and head seal ring (72), as instructed in steps 4 through 6 above.

## PUMP ASSEMBLY

**Before reassembling the pump, inspect all component parts for wear or damage, and replace as required. Wash out the stuffing box of the head and remove any burrs or nicks from the rotor and shaft.**

1. Begin assembly on the **outboard** (non-drive) side of the pump first by positioning the pump cylinder with the INTAKE port to the **left**.
2. Inspect the sleeve bearings (24) in both heads for damage or wear. If damaged or worn, bearings MUST be replaced.

### To replace sleeve bearings:

- a. Using an appropriately sized arbor press, remove the old bearing from the head.

## MAINTENANCE

- b. To aid installation and prevent damage to the bearing, heat the head in an oven to 200°F (93°C).
- c. Coat the new bearing with a quality grade of bearing grease, and place it on the inside face of the head with the notched end UP. See Figure 4.
- d. Using an arbor press, CAREFULLY press the bearing into the head in one continuous motion until it is flush with the inside face of the head. Ensure that the bearing does not become misaligned during the pressing activity.

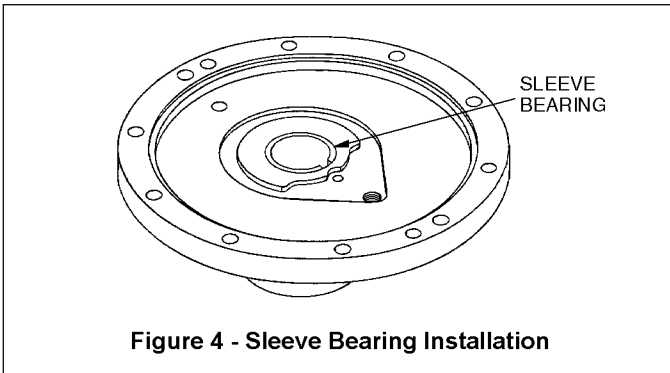

Figure 4 - Sleeve Bearing Installation

3. Align the disc with the dowel pin in the head and install the disc on the outboard head (23) so that the DISC DRAIN hole will be towards the INTAKE (suction) side of the pump when the head is installed on the cylinder. See Figure 5.
4. Install a new head seal ring (72) in the groove on the inside face of the head, around the outside diameter of the disc.
5. Carefully place the outboard head assembly on the pump cylinder using the alignment dowels for proper positioning. Ensure the disc drain hole faces the INTAKE (suction) side of the pump as shown in Figure 5.

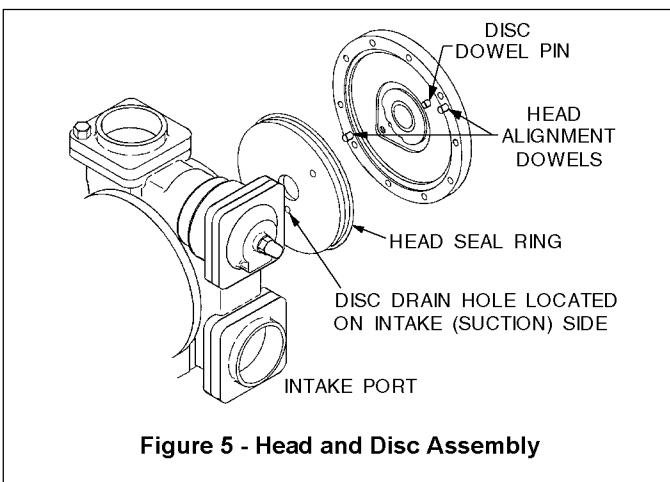

Figure 5 - Head and Disc Assembly

6. Lubricate the outboard head capscrews (21) with a quality grade of anti-seize compound. Install the head capscrews and uniformly tighten, torquing to 15 lbs ft (20.3 Nm).
7. Install a new bearing cover seal ring (26) and place the bearing cover (27) on the outboard head. Lubricate the bearing cover capscrews (28) with a quality grade of anti-seize compound and install, torquing to 11 lbs ft (15 Nm).

8. Turn the pump cylinder around and begin assembly on the opposite, inboard end.
9. Remove the vanes (14) and push rods (77) from the rotor and shaft assembly. Inspect for wear and damage, and replace as follows:
  - a. Insert vanes (14) into the bottom three rotor slots with the rounded edges facing outward, and the relief grooves facing TOWARDS the direction of rotation. Refer to Figure 2 for proper vane orientation.
  - b. Hold the vanes in place while inserting the three (3) push rods (77) from the top as shown in Figure 6.
  - c. While holding the vanes and push rods in place, carefully insert the non-driven end (shorter end) of the rotor and shaft into the open end of the pump cylinder.
  - d. Install the remaining vanes into the top positions of the rotor with the rounded edges facing outward, and the relief grooves facing TOWARDS the direction of rotation.

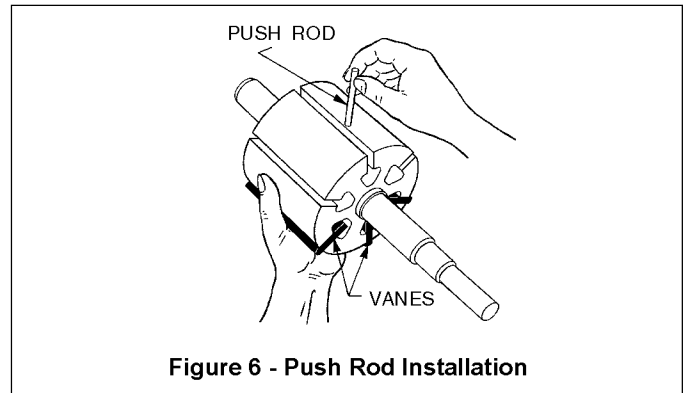

Figure 6 - Push Rod Installation

10. Install the inboard head (20), disc (71), and head seal ring (72), as instructed in steps 2 through 6. Apply a thin coating of motor oil on the inboard shaft to aid installation.
11. **If equipped with packing**, use a full set of new packing rings when reassembling the pump. Packing is furnished in sets with the correct number of rings. **DO NOT** add new rings to an old set of packing. To install packing:
  - a. Insert the pack washer (58) into the stuffing box of the inboard head (20).
  - b. Insert each of the packing rings (19) separately into the stuffing box, staggering the split joints 180 degrees, so that they are not overlapping or near the joint of the preceding ring. Use the packing follower to properly seat each ring after placement.
  - c. After all of the packing rings are in place, slide the packing follower (75) against the packing. Install and hand-tighten the stud nuts (18) evenly.

**NOTE:** Adjustment to the packing follower should be made after running the pump for 10-15 minutes (see "Packing Adjustment").

12. **If equipped with a commercial mechanical seal**, refer to the separate mechanical seal installation instructions for assembly.

# MAINTENANCE

## 13. SHAFT SUPPORT BEARING

- a. If removed, screw the short threaded ends of the two hex flange rods (106E) firmly into the tapped holes in the inboard head.
- b. Place the bearing flange (106) on the studs and install and tighten the locknuts (106A).
- c. Slide the bearing (106B) on the shaft until it is fully seated against the bearing flange. Install the lock collar over the shoulder of the bearing.
- d. Push the bearing firmly against the lock collar while turning the lock collar by hand in the direction of shaft rotation. Lock the collar to the shaft by tapping it in the direction of pump rotation with a punch tool and hammer (refer back to Figure 3).
- e. Tighten the set screw in the bearing lock collar (106B).
- f. Attach the bearing flange cover (106C) and install the bearing flange capscrews (106D).
- g. After installation of the shaft support bearing, the rotor & shaft **MUST** turn freely when rotated by hand. If it does not turn freely, loosen the lock collar and make sure the bearing is firmly seated in the housing. Re-tighten the lock collar and test again.

## 14. PACKING ADJUSTMENT

It is important that the packing be properly adjusted to prevent overheating.

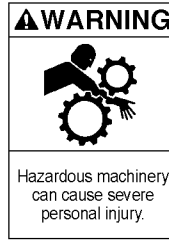

**FAILURE TO STOP THE PUMP BEFORE ADJUSTING THE SHAFT PACKING CAN CAUSE SEVERE PERSONAL INJURY.**

- a. While the liquid is being pumped, check for leakage from the stuffing box. If necessary, **STOP** the pump and uniformly tighten the packing follower stud nuts (18)  $\frac{1}{4}$  turn at a time to reduce leakage.
- b. Restart the pump and check the stuffing box temperature several minutes after each adjustment for signs of overheating.
- c. Repeat steps a and b until leakage is controlled, and no excess heat develops.
- d. Check the packing again after 20 to 30 minutes of running the pump, and readjust, if necessary.

**NOTE:** Some leakage is desirable to lubricate the packing, but in some cases it is unacceptable, depending on the application. A commercial mechanical seal should be used for applications requiring minimal shaft leakage.

## GENERAL PUMP TROUBLESHOOTING

### NOTICE:

MAINTENANCE SHALL BE PERFORMED BY QUALIFIED TECHNICIANS ONLY, FOLLOWING THE APPROPRIATE PROCEDURES AND WARNINGS AS PRESENTED IN THIS MANUAL.

SYMPTOM	PROBABLE CAUSE
<b>Pump Not Priming</b>	<ol style="list-style-type: none"> <li>1. Pump not wetted.</li> <li>2. Worn vanes.</li> <li>3. Suction valve closed.</li> <li>4. Air leaks in the suction line.</li> <li>5. Strainer clogged.</li> <li>6. Suction line or valves clogged or too restrictive.</li> <li>7. Broken drive train.</li> <li>8. Pump vapor-locked.</li> <li>9. Pump speed too low for priming.</li> <li>10. Relief valve partially open, worn or not seating properly.</li> </ol>
<b>Reduced Capacity</b>	<ol style="list-style-type: none"> <li>1. Pump speed too low.</li> <li>2. Suction valves not fully open.</li> <li>3. Air leaks in the suction line.</li> <li>4. Excessive restriction in the suction line (i.e.: undersized piping, too many elbows &amp; fittings, clogged strainer, etc.).</li> <li>5. Damaged or worn parts.</li> <li>6. Excessive restriction in discharge line causing partial flow through the relief valve.</li> <li>7. Relief Valve worn, set too low, or not seating properly.</li> <li>8. Vanes installed incorrectly (see "Vane Replacement").</li> </ol>

*continued on following page*

# GENERAL PUMP TROUBLESHOOTING

SYMPTOM	PROBABLE CAUSE
<b>Noise</b>	<ol style="list-style-type: none"> <li>1. Excessive vacuum on the pump due to:               <ol style="list-style-type: none"> <li>a. Undersized or restricted fittings in the suction line.</li> <li>b. Pump speed too fast for the viscosity or volatility of the liquid.</li> <li>c. Pump too far from fluid source.</li> </ol> </li> <li>2. Running the pump for extended periods with a closed discharge line.</li> <li>3. Pump not securely mounted.</li> <li>4. Improper drive line (see "Pump Drive").</li> <li>5. Sleeve Bearings worn or damaged.</li> <li>6. Vibration from improperly anchored piping.</li> <li>7. Bent shaft, or drive coupling misaligned.</li> <li>8. Excessively worn rotor.</li> <li>9. Malfunctioning valve in the system.</li> <li>10. Relief valve setting too low.</li> <li>11. Damaged vanes (see following category).</li> </ol>
<b>Damaged Vanes</b>	<ol style="list-style-type: none"> <li>1. Foreign objects entering the pump.</li> <li>2. Running the pump dry for extended periods of time.</li> <li>3. Cavitation.</li> <li>4. Viscosity too high for the vanes and/or the pump speed.</li> <li>5. Incompatibility with the liquids pumped.</li> <li>6. Excessive heat.</li> <li>7. Worn or bent push rods, or worn push rod holes.</li> <li>8. Settled or solidified material in the pump at start-up.</li> <li>9. Hydraulic hammer - pressure spikes.</li> <li>10. Vanes installed incorrectly (see "Vane Replacement").</li> </ol>
<b>Broken Shaft</b>	<ol style="list-style-type: none"> <li>1. Foreign objects entering the pump.</li> <li>2. Viscosity too high for the pump speed.</li> <li>3. Relief valve not opening.</li> <li>4. Hydraulic hammer - pressure spikes.</li> <li>5. Pump/driver misalignment.</li> <li>6. Excessively worn vanes or vane slots.</li> <li>7. Settled or solidified material in the pump at start-up.</li> </ol>
<b>Mechanical Seal Leakage (if equipped)</b>	<ol style="list-style-type: none"> <li>1. Seal Rings/O-rings not compatible with the liquids pumped.</li> <li>2. Seal Rings/O-rings nicked, cut or twisted.</li> <li>3. Shaft at seal area damaged, worn or dirty.</li> <li>4. Excessive cavitation.</li> <li>5. Mechanical seal faces cracked, scratched, pitted or dirty.</li> <li>6. Pump sleeve bearings worn excessively.</li> </ol> <p style="margin-top: 10px;"><b>NOTE: Consult commercial mechanical seal manufacturer for more information on mechanical seal troubleshooting.</b></p>

# ***blackmer***

A **DOVER** RESOURCES COMPANY

1809 Century Avenue, Grand Rapids, Michigan 49509 U.S.A.  
 Telephone: (616) 241-1611 • Fax: (616) 241-3752