

TRIPLE-LIP CARTRIDGE SEAL PARTS AND INSTRUCTIONS PUMP MODELS: NP1.5B, NP2F, NP3F, NP4F, SNP(J)1.5, SNP(J)2, SNP(J)2.5 SNP3A, MLN4B

Effective
Replaces

June 2003
NEW



This is a SAFETY ALERT SYMBOL.

When you see this symbol on the product, or in the manual, look for one of the following signal words and be alert to the potential for personal injury, death or major property damage



Warns of hazards that WILL cause serious personal injury, death or major property damage.



Warns of hazards that CAN cause serious personal injury, death or major property damage.



Warns of hazards that CAN cause personal injury or property damage.

NOTICE:

Indicates special instructions which are very important and must be followed.

NOTICE:

Blackmer pumps **MUST** only be installed in systems which have been designed by qualified engineering personnel. The system **MUST** conform to all applicable local and national regulations and safety standards.

This manual is intended to assist in the installation and operation of the Blackmer pumps, and **MUST** be kept with the pump.

Blackmer pump service shall be performed by qualified technicians **ONLY**. Service shall conform to all applicable local and national regulations and safety standards.

Thoroughly review this manual, all instructions and hazard warnings, **BEFORE** performing any work on the pump.

Maintain **ALL** system and Blackmer pump operation and hazard warning decals.

WARNING



Hazardous pressure can cause personal injury or property damage

DISCONNECTING FLUID OR PRESSURE CONTAINMENT COMPONENTS DURING PUMP OPERATION CAN CAUSE SERIOUS PERSONAL INJURY, DEATH OR MAJOR PROPERTY DAMAGE

WARNING



Hazardous voltage. Can shock, burn or cause death.

FAILURE TO DISCONNECT AND LOCKOUT ELECTRICAL POWER BEFORE ATTEMPTING MAINTENANCE CAN CAUSE SHOCK, BURNS OR DEATH

WARNING



Hazardous machinery can cause serious personal injury.

FAILURE TO DISCONNECT AND LOCKOUT ELECTRICAL POWER OR ENGINE DRIVE BEFORE ATTEMPTING MAINTENANCE CAN CAUSE SEVERE PERSONAL INJURY OR DEATH

WARNING



Hazardous pressure can cause serious personal injury or property damage

FAILURE TO RELIEVE SYSTEM PRESSURE PRIOR TO PERFORMING PUMP SERVICE OR MAINTENANCE CAN CAUSE SERIOUS PERSONAL INJURY OR PROPERTY DAMAGE.

WARNING



Hazardous machinery can cause severe personal injury or property damage

FAILURE TO SET THE VEHICLE EMERGENCY BRAKE AND CHOCK WHEELS BEFORE PERFORMING SERVICE CAN CAUSE SEVERE PERSONAL INJURY OR PROPERTY DAMAGE.

WARNING



Hazardous or toxic fluids can cause serious injury.

IF PUMPING HAZARDOUS FLUIDS, SYSTEM MUST BE FLUSHED, PRIOR TO PERFORMING SERVICE OR MAINTENANCE

SAFETY RULES

NOTICE:

THE APPROPRIATE BLACKMER PUMP MANUAL AND PARTS LIST MAY BE OBTAINED FROM THE BLACKMER WEBSITE (WWW.BLACKMER.COM) OR BY CONTACTING BLACKMER CUSTOMER SERVICE.

NOTICE:

MAINTENANCE AND TROUBLE SHOOTING MUST BE DONE BY AN INDIVIDUAL EXPERIENCED WITH PUMP MAINTENANCE AND THE TYPE OF SYSTEM INVOLVED.

NOTICE:

THE FOLLOWING INSTRUCTIONS INCLUDE ONLY THE STEPS NECESSARY TO REMOVE AND REPLACE THE BLACKMER TRIPLE-LIP CARTRIDGE SEAL. BEFORE PROCEEDING, READ AND FOLLOW ALL MECHANICAL SEAL RELATED INSTRUCTIONS AND HAZARD WARNINGS PROVIDED IN THE APPROPRIATE PUMP "INSTALLATION, OPERATION AND MAINTENANCE" MANUAL.

INSTALLATION INSTRUCTIONS FOR A TRIPLE-LIP CARTRIDGE SEAL

Satisfactory sealing is achieved only when shaft/ sleeve, bore and surrounding machine parts are in good mechanical condition. Shaft misalignment, runout and other operating factors also have an important bearing on performance.

1. Clean shaft (13) and the face of the inboard head (20) in and around the packing area (stuffing box).
2. Check shaft (13) for sharp corners, burrs, nicks or other imperfections. Use a file or sandpaper to remove any burrs or raised surface. Also, file sharp edges to prevent cutting O-ring. Keyways should be covered or filled with a suitable filler to protect the O-rings from damage during installation.
3. Check shaft alignment. Runout must not exceed .005 (.13 mm) T.I.R.
4. The enclosed lubricant should be applied to the O-rings on the inside of the sleeve. This will assist the cartridge seal to slide freely over the shaft during installation.
5. Be sure to place the gasket (222) between the cartridge seal (223) & inboard head (20), then ease the cartridge seal over the shaft (13) up to the face of the inboard head.
6. Use flat washers (234) under the gland capscrews (233) and lightly snug the cartridge seal & gasket to the face of the inboard head (20) at the packing area (stuffing box).
7. Insure that the sleeve/drive collar (221) is pressed forward and nested against the clip wings. (See Figure 1)
8. Check to insure all clip wings are positioned at 90° to the shaft and providing absolute centering of the drive collar. (221) (See Figure 2)
9. Set the set screws to the shaft as follows:
Run each setscrew in until it just touches the shaft. Tighten each setscrew in an opposing pattern to avoid pulling the sleeve off center.
10. Insure that the clip wings are at 90° to the shaft and while rotating the shaft (by hand) insure that the drive collar is not rubbing or binding against one or two of the centering clips more than the rest. Use .001" or .002" (.03-.05 mm) feeler gauge and test the gap between the clips and drive collar. (See Figure 1).

Note: The feeler gauge should not pass between the clip(s) and the drive collar at any location. If it appears that a clip wing or two are tipped away from the drive collar, it indicates that the gland bolting is uneven. Tighten the bolt(s) on the opposite side from the tilted clip wing/gap and watch as the clip wing squares to the drive collar shoulder.

11. If an adjustment is required, loosen the gland capscrews (233) and move the seal slightly to achieve centering and re-tighten the gland capscrews (233).
12. Repeat the process until the seal is centered on the shaft.
13. Evenly tighten the gland capscrews (233) in a criss-cross pattern.
14. Rotate the clip wings 90° (See Figure 2)
15. Rotate shaft (13) to ensure the seal is in proper working order.
16. Install environmental controls or plug the flush ports. (See Figure 4)

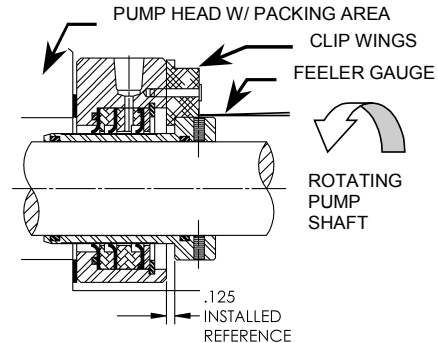

Figure 1
CLIP WINGS

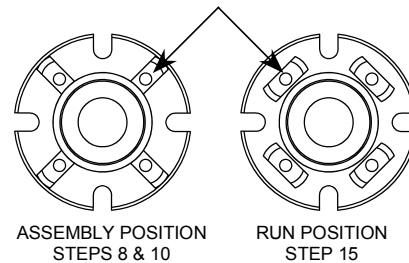

Figure 2

REPAIR KIT INSTRUCTIONS FOR A TRIPLE-LIP CARTRIDGE SEAL

Satisfactory sealing is achieved only when all existing components are in good mechanical condition. Seal rebuild kits contain the only component parts listed

Before rebuilding the cartridge seal, remove the cartridge seal from pump, disassemble & clean those components **NOT** provided in the Seal Rebuild Kit. Discard the used components that will be replaced with components in the Seal Rebuild Kit.

NOTE: Examine the sleeve's (221) coated surface carefully. It should be free from scratches and other noticeable damage.

1. Place items into the gland bore as shown as in Figure 3. Be sure to align the flush spacer (227) correctly. Once the snap ring (230) is in place, carefully slide the sleeve (221) with O-rings (220) and set screws (231) installed through the gland as shown. The clip wings will align the sleeve (221) with the seal.
2. Follow the installation instructions to install the rebuilt seal

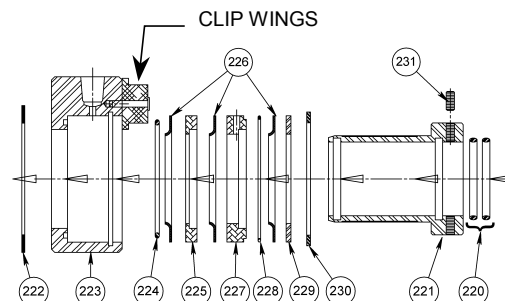
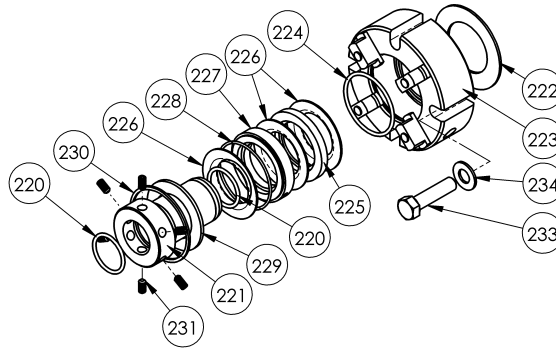

Figure 3



TRIPLE-LIP CARTRIDGE SEAL – STRAIGHT SHAFT

Pump Models		NP1.5		NP2		SNP2		NP2.5, NP3, SNP3		NP4	
Ref. No.	Part Name	Seal	Seal Rebuild Kit	Seal	Seal Rebuild Kit	Seal	Seal Rebuild Kit	Seal	Seal Rebuild Kit	Seal	Seal Rebuild Kit
—	TRIPLE-LIP CARTRIDGE SEAL	331214	899102	331773	899104	333814	899101	331774	899105	331948	899107
220	Shaft Sleeve O-Ring	2	X	2	X	2	X	2	X	2	X
221	Shaft Sleeve	1		1		1		1		1	
222	Gasket	1	X	1	X	1	X	1	X	1	X
223	Gland Plate Assembly	1		1		1		1		1	
224	Element O-Ring	1	X	1	X	1	X	1	X	1	X
225	Seal Spacer	1	X	1	X	1	X	1	X	1	X
226	Seal Element	3	X	3	X	3	X	3	X	3	X
227	Flushing Spacer	1	X	1	X	1	X	1	X	1	X
228	Flushing Spacer O-Ring	1	X	1	X	1	X	1	X	1	X
229	Retaining Ring	1		1		1		1		1	
230	Snap Ring	1	X	1	X	1	X	1	X	1	X
231	Shaft Sleeve Setscrews	6	X	6	X	6	X	6	X	6	X
233	Gland Capscrew	4	X	4		4		4	X	4	
234	Flat Washer	4	X	4		4		4	X	4	

X= Component included in Seal Rebuild Kit

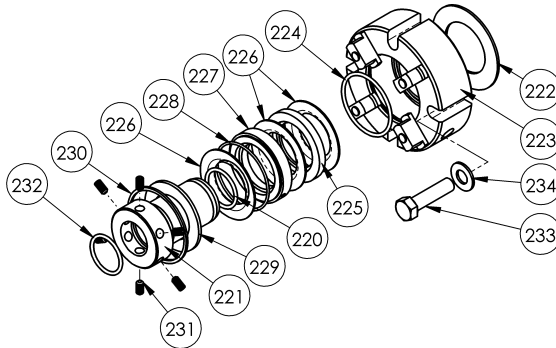

TRIPLE-LIP CARTRIDGE SEAL – STEPPED SHAFT

Pump Models		SNP1.25, SNP1.5		SNP(J)2.5		MLN4	
Ref. No.	Part Name	Seal	Seal Rebuild Kit	Seal	Seal Rebuild Kit	Seal	Seal Rebuild Kit
—	TRIPLE-LIP CARTRIDGE SEAL	333114	899100	335314	899103	337003	899106
220	Shaft Sleeve O-Ring	1	X	1	X	1	X
221	Shaft Sleeve	1		1		1	
222	Gasket	1	X	1	X	1	X
223	Gland Plate Assembly	1		1		1	
224	Element O-Ring	1	X	1	X	1	X
225	Seal Spacer	1	X	1	X	1	X
226	Seal Element	3	X	3	X	3	X
227	Flushing Spacer	1	X	1	X	1	X
228	Flushing Spacer O-Ring	1	X	1	X	1	X
229	Retaining Ring	1		1		1	
230	Snap Ring	1	X	1	X	1	X
231	Shaft Sleeve Setscrews	6	X	6	X	6	X
232	Stepped Shaft Sleeve O-Ring	1	X	1	X	1	X
233	Gland Capscrew	4		4		2	
234	Flat Washer	4		4		2	

X= Component included in Seal Rebuild Kit

Environmental Control Options

Consult Factory for Specific Information.

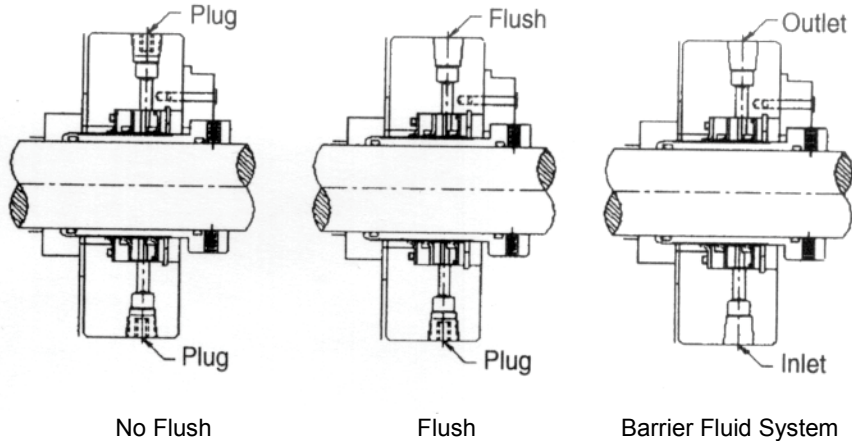

Figure 4



1809 Century Avenue, Grand Rapids, Michigan 49503-1530 U.S.A.
Telephone: (616) 241-1611 • Fax: (616) 241-3752
E-mail: blackmer@blackmer.com • Internet Address: www.blackmer.com

Form 561
Page 4 of 4